



**SAMURAI NEXT GEN
ELECTRIC WINCH**

S8000 S9500

S12000 S14500

S9500SD

S9500HS

Assembly & Operating Instructions

CONTENTS

INTRODUCTION.....	1
GETTING TO KNOW YOUR WINCH	1
WINCH ASSEMBLY AND MOUNTING.....	3
SAFETY PRECAUTIONS.....	5
GENERAL TIPS FOR SAFE OPERATION	6
RIGGING TECHNIQUES	7
WINCHING TECHNIQUES A-Z	8
MAINTENANCE.....	9
REPLACING THE WIRE ROPE.....	10
TROUBLE SHOOTING	10
WINCH ASSEMBLY DRAWING (S8000)	11
WINCH PARTS LIST (S8000)	12
WINCH ASSEMBLY DRAWING (S9500)	13
WINCH PARTS LIST (S9500)	14
WINCH ASSEMBLY DRAWING (S12000)	15
WINCH PARTS LIST (S12000)	16
WINCH ASSEMBLY DRAWING (S14500)	17
WINCH PARTS LIST (S14500)	18
WINCH ASSEMBLY DRAWING (S9500SD)	19
WINCH PARTS LIST (S9500SD)	20
WINCH ASSEMBLY DRAWING (S9500HS)	21
WINCH PARTS LIST (S9500HS)	22
SPECIFICATION (S8000)	23
SPECIFICATION (S9500)	24
SPECIFICATION (S12000)	25
SPECIFICATION (S14500)	26
SPECIFICATION (S9500SD)	27
SPECIFICATION (S9500HS)	28
WARRANTY.....	29

INTRODUCTION

Congratulations on your purchase of a winch. We design and build winches to strict specifications and with proper use and maintenance your winch should bring you years of satisfying service.

⚠️ WARNING - Read, study and follow all instructions before operating this device. Failure to heed these instructions may result in personal injury and/or property damage.

Your winch can develop tremendous pulling forces and if used unsafely or improperly could result in property damage, serious injury or death. Throughout this manual, you will find the following symbols for caution, warning and danger. Pay particular attention to the notes preceded by these symbols as they are written for your safety. Ultimately, safe operation of this device rests with you, the operator.



Indicates a potentially hazardous situation which, if not avoided, may result in minor or moderate injury. This notation is also used to alert against unsafe practices.



Indicates a potentially hazardous situation which, if not avoided could result in death or serious injury.

GETTING TO KNOW YOUR WINCH

Your winch is a powerful piece of machinery. It is important that you understand the basics of its operation and specifications so that when you need to use it, you can use it with confidence and safety. Below is a list of the components of your winch and their uses. Practice using your winch before you are in a situation to need to use it.

1. This winch is engineered for maximum line pull with only one layer of cable spooled onto the winch drum (the first layer).
2. Motor: Your motor is powered by a 12/24-volt battery and provides power to the gear mechanism which turns the drum and winds the wire rope;

3. Winch Drum: The winch drum is the cylinder on which the wire rope is stored. It can feed out or wind in the rope by use of the remote winch switch.
4. Wire Rope: Your winch has a galvanized aircraft cable designed specifically for load capacity of the rated line pull of this winch. The wire rope feeds onto the drum in the “under wind” position through the roller fairlead and is looped at the end to accept the clevis hook pin.
5. Roller Fairlead: When using the winch at an angle the roller fairlead acts to guide the wire rope onto the drum and minimizes damage to the wire rope from abrasion on the winch mount or bumper.
6. Mechanical Gear System: The reduction gears convert the winch motor power into extreme pulling forces.
7. Braking System: Braking action is automatically applied to the winch drum when the winch motor is stopped and there is a load on the wire rope. This is achieved by a separate mechanical brake which applies the braking action.
8. Free Spooling Clutch: The clutch allows the operator to manually disengage (“CLUTCH OUT”) the spooling drum from the gear train. This called free spool. Engaging the clutch (“CLUTCH IN”) locks the winch into the gear system.
9. Solenoid: Power from the vehicle battery flows through the weather-sealed switch before being directed to the winch motor.
10. Remote Switch: The power switch leads have a dual switch for powering in or powering out your winch drum. The remote control allows you to stand clear of the wire rope when the winch is under load.
11. The wireless remote control allows you to control the winch from up to 50 Ft away.
12. Universal Flat Bed Mounting Channel: Your winch could have been optionally supplied with a flat bed mounting channel that can be mounted to most flat surfaces such as trailers, step bumpers, truck beds, etc. The mounting channel also has holes to accept your roller fairlead.
13. Snatch Block: If your winch is supplied with a snatch block which can double the pulling power of the winch, or change the pulling direction without damaging the wire rope. We recommend you to use double line and snatch block for pulling over 70% of the rated line pull.

WINCH ASSEMBLY AND MOUNTING

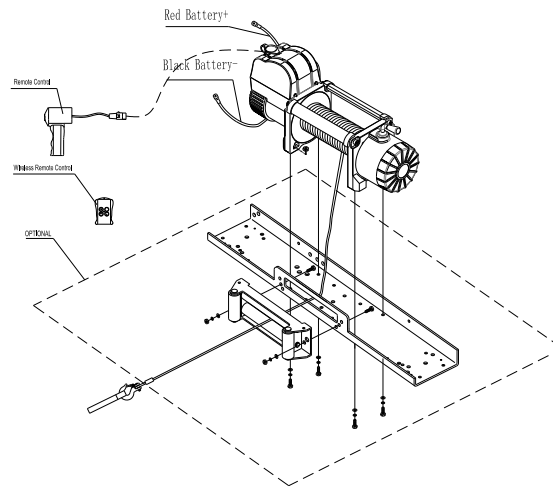

1. Your winch is designed with a bolt pattern that is standard in this class of winch. Many winch mounting kits are available that utilize this bolt pattern for the most popular vehicle and mounting channels. If you cannot find a kit locally, contact us and we will provide you with the name of a dealer near you. If you utilize the mounting channel you must ensure that it is mounted on a flat surface so that the three major sections (motor, drum and gear housing) are properly aligned. Proper alignment of the winch will allow even distribution of the full rated load.
2. Start by connecting the Roller Fairlead to the Mounting Channel using 2 each of the Cap Bolt M10 X 35, Flat Washer, Lock Washer and securing with M10 Nut (Make sure the bolt is placed through the mounting channel and roller fairlead from inside the channel. This will allow enough clearance for the winch to be placed in the channel without obstruction.)
3. Assemble the winch to the Mounting Channel by first pulling and releasing the clutch knob to "Off" position (Free Spooling). Pull out a few inches of cable from the drum and feed the wire loop through the opening in the front of the mounting channel and roller fairlead. Now, using the remaining M10 x 35 Cap Bolts, Flat Washer, Lock Washer and M10 Nut secure the winch to the mounting channel.
4. Connect the battery and motor leads as the drawing above. Remember every type of winch is different.
5. Connect the winch motor leads as detailed below:

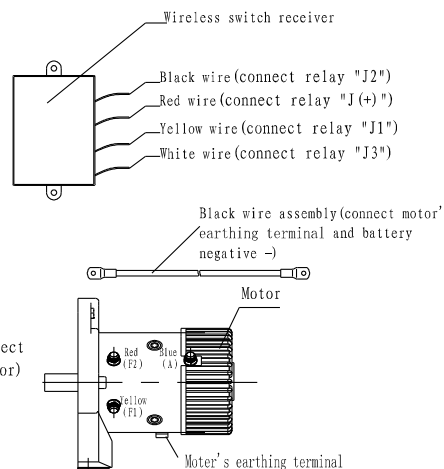
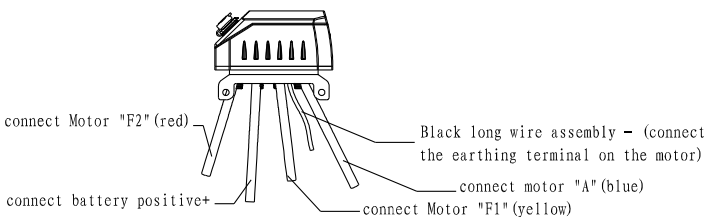
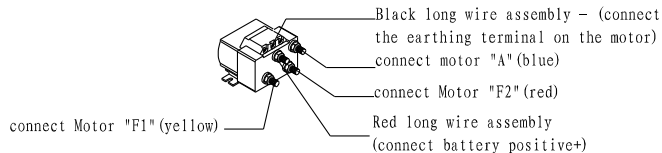
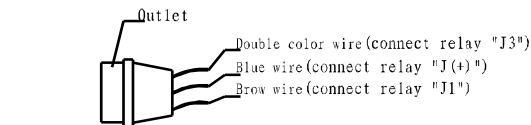
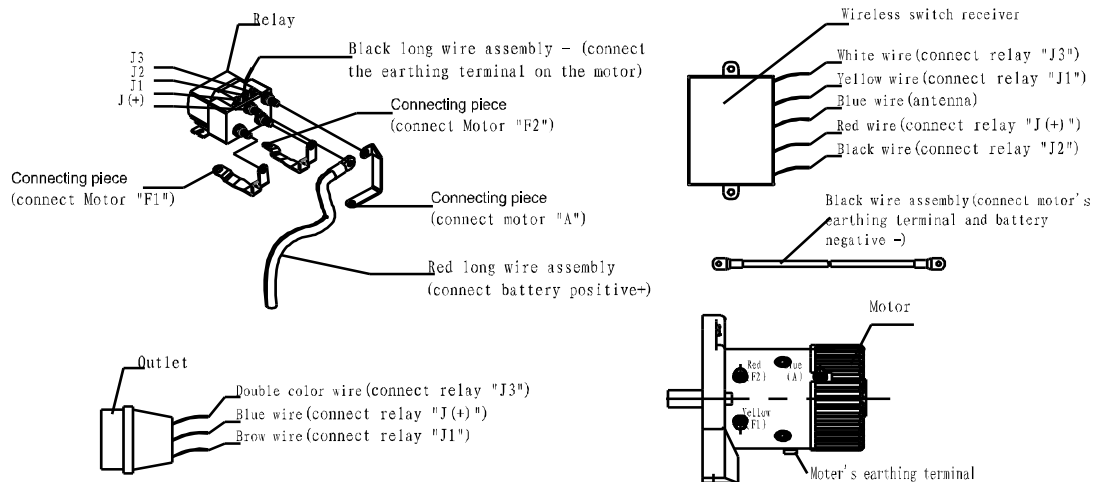

⚠ CAUTION – Batteries contain gases which are flammable and explosive. Wear eye protection during installation and remove all jewelry. Do not lean over battery while making connections.

6. Assemble the Clevis Hook to the cable. Take off the pin from the Clevis Hook, connect the Clevis Hook to the cable and mount the pin back to the Clevis Hook.
7. Always use the Hand Saver when free-spooling and re-spooling the wire rope. Using the Hand Saver keeps your hands and fingers away from the rotating drum.
8. Check for proper drum rotation. Pull and turn the clutch knob to the “off” position (Free-spooling). Pull out some cable from the drum, and then turn the clutch knob to the “In” position to engage the gears. Press the cable out button on the power switch. If the drum is turning and releasing cable, then your connections

are accurate. If the drum is turning and collecting more cable, then reverse the leads on the motor. Repeat and check rotation.

SAFETY PRECAUTIONS

⚠️ WARNING ⚠️

- ⚠️ WARNING – DO NOT EXCEED RATED CAPACITY.**
- ⚠️ WARNING – Intermittent use only.**
- ⚠️ WARNING - Do not use winch for lifting or moving people.**
- ⚠️ WARNING - A minimum of five wraps of cable around the drum barrel is necessary for pulling and holding the rated load. The cable clamp is not designed to hold the load without the 5 wraps of cable around the barrel.**
- ⚠️ WARNING - Keep yourself and others a safe distance to the side of the cable when under tension.**
- ⚠️ WARNING – The wire rope may break before the motor stalls. For heavy loads at or near rated capacity, use a pulley block/snatch block to reduce the load on the wire rope.**
- ⚠️ WARNING -Never step over a cable, or near a cable under load.**
- ⚠️ WARNING - Don't move the vehicle to pull a load (towing) on the winch cable. This could result in cable breakage.**
- ⚠️ WARNING-Disconnect the remote control and battery leads when not in use.**
- ⚠️ WARNING- Do not exceed maximum pull rating. Avoid “shock loads” by using the control switch intermittently to take up the slack in the wire rope. “Shock loads” can far exceed the rated capacity for the wire rope and drum.**
- ⚠️ WARNING- Do not exceeds maximum line pull ratings shown on the tables.**
- ⚠️ WARNING-When re-spooling the cable, ensure that the cable spools in the under-wind position with the cable entering the drum from the bottom, not the top. To re-spool correctly, and while wearing gloves, keep a slight load on the cable while pushing the remote control button to draw in the cable. Walk toward the winch not allowing the cable to slide through your hands. Do not let your hands get within 12”(30cm) of the winch while re-spooling.**

Turn off the winch and repeat the procedure until a few feet of cable is left. Disconnect the remote control and finish spooling by hand by rotating the drum manually with the clutch disengaged. Keep hands clear of the fairlead and drum while the winch is under power.

 Do not use as a hoist. Do not use for overhead lifting.

 Failure to heed these warnings may result in personal injury and/or property damage.

 **WARNING** - Use gloves to protect hands when handling the cable. Never let the cable slide through your hands.

 **WARNING** – Never connect the cable back to itself.

Apply blocks to the wheels of the vehicle when on an incline.

No modifications, alterations, or deviation to the winch are authorized by the manufacturer and **MUST** not be made.

Duration of winching pulls should be kept as short as possible. If the motor becomes uncomfortably hot to the touch, stop winching immediately and let it cool down for a few minutes. Do not pull for more than one minute at or near the rated load.  **CAUTION** - If the motor stalls do not maintain power to the

winch. Electric winches are designed and made for intermittent use and should not be used in constant duty applications.

 **CAUTION** - Never release the free-spool clutch when there is a load on the winch.

 **CAUTION** - Use hand saver hook when handling the hook for spooling or un-spooling the wire rope.

GENERAL TIPS FOR SAFE OPERATION

- The winch and its all-derivative types are rated at rated capacity when spooling the first rope layer on the drum. Overloading can damage the winch/motor/ or wire rope. For loads over 70% of rated line pull, we recommend the use of the pulley block/snatch block to double the wire rope line. This will aid in two ways: It will reduce the number of rope layers on the drum and reduce the load on the wire rope by as much as 50%. When doubling the line back to the vehicle, attach to the frame or other load bearing part.

- The vehicle engine should be kept running during operation of the winch to minimize battery drain and maximize power and speed of the winch. If the winch is used for a considerable time with the engine switched off the battery may be drained and too weak to restart the engine
- Get to know your winch before you need to use it. We recommend that you set up a few test runs to familiarize yourself with rigging techniques; the sounds your winch makes under various loads and the way the cable spools on the drum, etc.
- Inspect the wire rope and equipment before each use. A frayed or damaged rope must be replaced immediately. Use only manufacturer's identical replacement rope with the exact specifications.
- Inspect the winch installation and bolts to ensure that all bolts are tight before each operation.
- Never connect the cable back to itself. This will cause cable damage. Always use a snatch block, sling or chain of suitable strength as shown in the illustrations.
- Store the remote control inside your vehicle in a safe place.
- Any winch that appears to be damaged in any way, is found to be worn, or operates abnormally **MUST BE REMOVED FROM SERVICE UNTIL REPAIRED**. It is recommended that the necessary repairs be made by a manufacturer's authorized repair facility.
- Pull only on areas of the vehicle as specified by the vehicle manufacturer.
- Only attachments and/or adapters supplied by the manufacturer shall be used.

RIGGING TECHNIQUES

Self Recovery

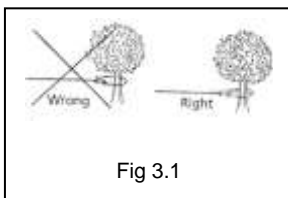

Locate a suitable anchor such as a strong tree trunk or boulder.

Always use a sling as an anchor point. **⚠ CAUTION** Do not attach the clevis hook back onto the cable as this could cause damage to the cable.

As shown in Fig 3.1

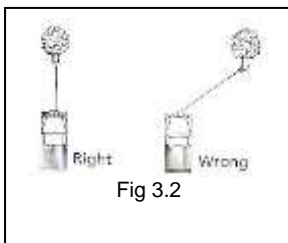

⚠ Do not winch from an acute angle as the wire rope will pile up on one side of the drum causing damage to wire rope and the winch.

Fig 3.2

Short pulls from an angle can be used to straighten the vehicle. Long pulls should be done with the wire rope at a 90° angle to the winch/vehicle.

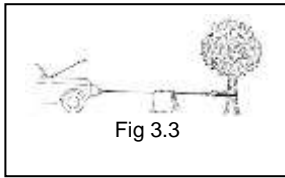

Fig 3.3

When pulling a heavy load, place a blanket or jacket over the wire rope five or six feet from the hook because in the event of a broken cable it will dampen the snap back. For additional protection open the hood/bonnet of the vehicle as shown in Fig 3.3

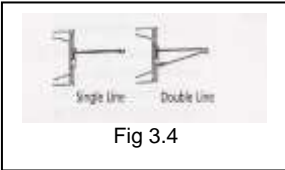

Fig 3.4

For pulls over 6800lbs, we recommend the use of the snatch block/pulley block to double line the wire rope. Fig 3.4

This reduces the load on the winch and the strain on the rope by approximately 50%.

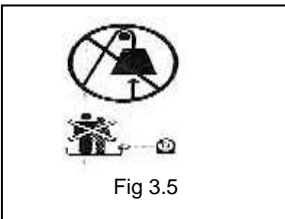

Fig 3.5

! **WARNING** - Never use your winch for overhead hoisting or for lifting people or moving people.

WINCHING TECHNIQUES A-Z

- a. Take time to assess your situation and plan your pull.
- b. Put on gloves to protect your hands.
- c. Disengage the clutch to allow free-spooling and also save battery power.
- d. Attach the hand saver hook to the clevis hook.
- e. Pull out the wire rope to your desired anchor point using the hand saver hook.
- f. Secure the clevis hook to the anchor point: Sling, chain or snatch block. Do not attach the hook back onto the wire rope.
- g. Engage the clutch.
- h. Connect the remote control to the winch.
- i. Start your engine to ensure power is being replenished to the battery.
- j. Power in the wire rope guiding the wire under tension to draw up the slack in the wire. Once the wire is under tension stand well clear. Never step over the wire rope.
- k. Double check your anchors and make sure all connections are secure.
- l. Inspect the wire rope. Make sure there are at least 5 wraps of wire rope around the winch drum.
- m. Drape a blanket or jacket over the wire rope approximately 5 to 6 feet from the hook. Open the hood/bonnet for added protection.
- n. Clear the area. Make sure all spectators are well back and that no one is directly in front or behind the vehicle or anchor point.

- o. Begin winching. Be sure that the wire rope is winding evenly and tightly around the drum. The vehicle that is being winched can be slowly driven to add assistance to the winching process. Avoid shock loads; keep the wire rope under tension.
- p. The vehicle to be winched should be placed in neutral and the emergency brake released. Only release the brake pedal when under full tension. Avoid shock loads to the winch. This can damage the winch, rope and vehicle.
- q. The winch is meant for intermittent use. Under full load with a single line rig do not power in for more than a minute without letting the motor cool down for a few minutes and then resume the winching operation.
- r. The winching operation is complete once the vehicle is on stable ground and can drive under its own power.
- s. Secure the vehicle. Be sure to set the brakes and place the vehicle in park.
- t. Release the tension on the wire rope. The winch is not meant to hold the vehicle for long periods of time.
- u. Disconnect the wire rope from the anchor.
- v. Rewind the wire rope. Make sure that any wire already on the drum has spooled tightly and neatly. If not, draw out the wire and re-spool from the point where the rope is tight.
- w. Keep your hands clear of the winch drum and fairlead as the wire rope is being drawn in.
- x. Secure the hook and hook strap.
- y. Disconnect the remote control and store in a clean, dry place.
- z. Clean and inspect connections and mounting hardware for next winching operation.

MAINTENANCE

1. Periodically check the tightness of mounting bolts and electrical connections. Remove all dirt or corrosion and always keep clean.
2. Do not attempt to disassemble the gear box. Repairs should be done by the manufacturer or an authorized repair center.
3. The gear box has been lubricated using a high temperature lithium grease and is sealed at the factory. No internal lubrication is required.

REPLACING THE WIRE ROPE

1. If the wire rope has become worn or is beginning to show signs of fraying, it must be replaced before being used again. To do this, remove the defective rope by free spooling. Remove the bolt M8x10 on the drum and release the rope.
2. Insert the end of the new rope and secure the M8 x 10 mm bolt tightly.
3. Engage the clutch and re-spool the new rope on the drum keeping tension on the rope as it spools. Ensure that the rope is re-spooling in the under-wind position.

⚠ WARNING - Only replace the wire rope with the identical replacement part recommended by the manufacturer.

TROUBLE SHOOTING

SYMPTOM	POSSIBLE CAUSE	SUGGESTED ACTION
Motor does not turn on	-Switch Assembly connected improperly	-Reinsert switch assembly into the connector.
	-Loose battery cable connections	-Tighten nuts on all cable connections.
	-Defective switch assembly	-Replace switch assembly.
	-Defective motor	-Check for voltage at armature port with Switch pressed. If voltage is present, replace motor.
	-Water has entered motor	-Allow to drain and dry. Run winch until completely dry.
Motor runs but cable drum not turn	-Clutch not engaged	-Turn clutch to the “In” position. If problem persists, ask a technician to check and repair.
Motor runs slowly or without normal power	-Insufficient current or voltage	-Operate winch while vehicle motor running.
Motor overheating	-Winch running for too long	-Allow winch to cool down periodically.
Motor runs in one direction only	-Loose or corroded battery cable or motor cable connections.	-Clean and tighten. -Repair or replace switch assembly.

WINCH ASSEMBLY DRAWING(S8000)

WINCH PARTS LIST (S8000)

No.	Part #	Qty	Description	Remark
1	950100	1	Motor Assembly	
2	800001	6	Cap Screw M10 x 35	
3	800002	6	Lock Washer Φ 10	
4	800003	6	Think Flat Washer Φ 10	
5	800004	6	Hex Flange Nut M10	
6	1200200	1	Break / Shaft Assembly	
7	1200005	2	Bushing—Drum	
8	800006	2	Tie Bar	
9	800007	1	Screw M8 x 10	
10	800008	4	Think Flat Washer Φ 8	
11	800009	4	Cap Screw M8 x 30	
12	1200300	1	Drum Assembly	
13	800010	8	Screw M5 x18	
14	800011	8	Lock Washer Φ 5	
15	1200012	1	End Bearing	
16	800013	1	Gasket	
17	800014	1	Gear—Ring	
18	800400	1	Gear Carrier Assembly (Input)	
19	800500	1	Gear Carrier Assembly (Intermediate)	
20	800600	1	Gear Carrier Assembly (Output)	
21	800015	1	Gear—Input Sun	
22	800016	1	Trust Washer	
23	800017	1	Gear—Housing	
24	800018	1	Clutch Screw	
25	800019	1	Ring Seals	
26	800020	1	Clutch Cover	
27	1200021	1	Clutch	
28	800RS	1	Remote Control Switch (R8)	
29	800800	1	Cable Assembly	
30	80WRS	1	Wireless Remote Control Switch	
31	800900	1	Roller Fairlead	
32	800022	1	Mounting Play	800VS12/800VA12
33	800023	1	Connecting Piece	800VS12/800VA12
34	800024	1	Connecting Piece	800VS12/800VA12
35	801300	1	Wireless Switch Receiver	800VS12/800VA12
36	1201400	1	Relay with Screw Assembly	800VS12/800VA12
37	951500	1	Cover with Screw Assembly	800VS12/800VA12
38	800025	1	Connecting Piece	800VS12/800VA12
39	1200026	4	Connecting Block	
40	1200027	2	Connecting Rod Sets	
41	800028	2	Ring Seals	
42	801600	1	Control Assembly	
43	800029	1	Six angle bar	

WINCH PARTS LIST (S9500)

No.	Part #	Qty	Description	Remark
1	950100	1	Motor Assembly	
2	950001	6	Cap Screw M10 x 35	
3	950002	6	Lock Washer Φ 10	
4	950003	6	Thin Flat Washer Φ 10	
5	950004	6	Hex Flange Nut M10	
6	1200200	1	Break / Shaft Assembly	
7	1200005	2	Bushing—Drum	
8	950006	2	Tie Bar	
9	950007	1	Screw M8 x 10	
10	950008	4	Thin Flat Washer Φ 8	
11	950009	4	Cap Screw M8 x 30	
12	1200300	1	Drum Assembly	
13	950010	8	Screw M5 x18	
14	950011	8	Lock Washer Φ 5	
15	1200012	1	End Bearing	
16	950013	1	Gasket	
17	950014	1	Gear—Ring	
18	950400	1	Gear Carrier Assembly (Input)	
19	950500	1	Gear Carrier Assembly (Intermediate)	
20	950600	1	Gear Carrier Assembly (Output)	
21	950015	1	Gear—Input Sun	
22	950016	1	Trust Washer	
23	950017	1	Gear—Housing	
24	950018	1	Clutch Screw	
25	950019	1	Ring Seals	
26	950020	1	Clutch Cover	
27	1200021	1	Clutch	
28	950RS	1	Remote Control Switch (R8)	
29	950800	1	Cable Assembly	
30	95WRS	1	Wireless Remote Control Switch	
31	950900	1	Roller Fairlead	
32	950022	1	Mounting Play	950VS12/950VA12
33	950023	1	Connecting Piece	950VS12/950VA12
34	950024	1	Connecting Piece	950VS12/950VA12
35	951300	1	Wireless Switch Receiver	950VS12/950VA12
36	1201400	1	Relay with Screw Assembly	950VS12/950VA12
37	951500	1	Cover with Screw Assembly	950VS12/950VA12
38	950025	1	Connecting Piece	950VS12/950VA12
39	1200026	4	Connecting Block	
40	1200027	2	Connecting Rod Sets	
41	950028	2	Ring Seals	
42	951600	1	Control Assembly	
43	950029	1	Six angle bar	

WINCH ASSEMBLY DRAWING(S12000)

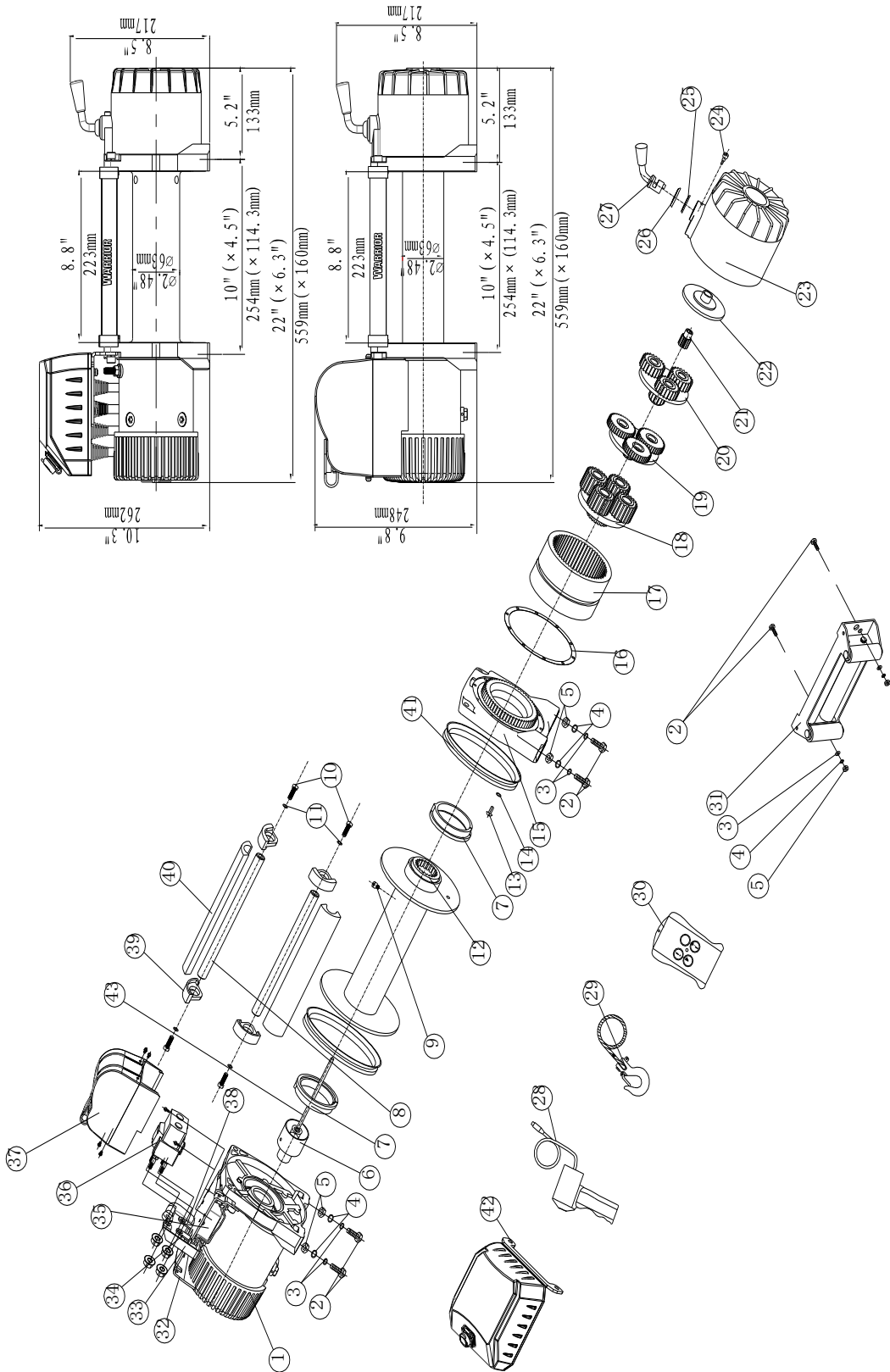

WINCH PARTS LIST (S12000)

No.	Part #	Qty	Description	Remark
1	1200100	1	Motor Assembly	
2	1200001	6	Cap Screw M10 x 35	
3	1200002	6	Lock Washer Φ 10	
4	1200003	6	Think Flat Washer Φ 10	
5	1200004	6	Hex Flange Nut M10	
6	1200200	1	Break / Shaft Assembly	
7	1200005	2	Bushing—Drum	
8	1200006	2	Tie Bar	
9	1200007	1	Screw M8 x 10	
10	1200008	4	Think Flat Washer Φ 8	
11	1200009	4	Cap Screw M8 x 30	
12	1200300	1	Drum Assembly	
13	1200010	8	Screw M5 x18	
14	1200011	8	Lock Washer Φ 5	
15	1200012	1	End Bearing	
16	1200013	1	Gasket	
17	1200014	1	Gear—Ring	
18	1200400	1	Gear Carrier Assembly (Input)	
19	1200500	1	Gear Carrier Assembly (Intermediate)	
20	1200600	1	Gear Carrier Assembly (Output)	
21	1200015	1	Gear—Input Sun	
22	1200016	1	Trust Washer	
23	1200017	1	Gear—Housing	
24	1200018	1	Clutch Screw	
25	1200019	1	Ring Seals	
26	1200020	1	Clutch Cover	
27	1200021	1	Clutch	
28	120RS	1	Remote Control Switch (R8)	
29	1200800	1	Cable Assembly	
30	120WRS	1	Wireless Remote Control Switch	
31	1200900	1	Roller Fairlead	
32	1200022	1	Mounting Play	120VS12/120VA12
33	1200023	1	Connecting Piece	120VS12/120VA12
34	1200024	1	Connecting Piece	120VS12/120VA12
35	1201300	1	Wireless Switch Receiver	120VS12/120VA12
36	1201400	1	Relay with Screw Assembly	120VS12/120VA12
37	1201500	1	Cover with Screw Assembly	120VS12/120VA12
38	1200025	1	Connecting Piece	120VS12/120VA12
39	1200026	4	Connecting Block	
40	1200027	2	Connecting Rod Sets	
41	1200028	2	Ring Seals	
42	1201600	1	Control Assembly	
43	1200029	1	Six angle bar	

WINCH PARTS LIST (S14500)

No.	Part #	Qty	Description	Remark
1	1450100	1	Motor Assembly	
2	1450001	6	Cap Screw M10 x 35	
3	1450002	6	Lock Washer Φ 10	
4	1450003	6	Thin Flat Washer Φ 10	
5	1450004	6	Hex Flange Nut M10	
6	1450200	1	Break / Shaft Assembly	
7	1450005	2	Bushing—Drum	
8	1450006	2	Tie Bar	
9	1450007	1	Screw M8 x 10	
10	1450008	4	Thin Flat Washer Φ 8	
11	1450009	4	Cap Screw M8 x 30	
12	1450300	1	Drum Assembly	
13	1450010	8	Screw M5 x18	
14	1450011	8	Lock Washer Φ 5	
15	1450012	1	End Bearing	
16	1450013	1	Gasket	
17	1450014	1	Gear—Ring	
18	1450400	1	Gear Carrier Assembly (Input)	
19	1450500	1	Gear Carrier Assembly (Intermediate)	
20	1450600	1	Gear Carrier Assembly (Output)	
21	1450015	1	Gear—Input Sun	
22	1450016	1	Trust Washer	
23	1450017	1	Gear—Housing	
24	1450018	1	Clutch Screw	
25	1450019	1	Ring Seals	
26	1450020	1	Clutch Cover	
27	1450021	1	Clutch	
28	145RS	1	Remote Control Switch (R8)	
29	1450800	1	Cable Assembly	
30	145WRS	1	Wireless Remote Control Switch	
31	1450900	1	Roller Fairlead	
32	1450022	1	Mounting Play	145VS12/145VA12
33	1450023	1	Connecting Piece	145VS12/145VA12
34	1450024	1	Connecting Piece	145VS12/145VA12
35	1451300	1	Wireless Switch Receiver	145VS12/145VA12
36	1451400	1	Relay with Screw Assembly	145VS12/145VA12
37	1451500	1	Cover with Screw Assembly	145VS12/145VA12
38	1450025	1	Connecting Piece	145VS12/145VA12
39	1450026	4	Connecting Block	
40	1450027	2	Connecting Rod Sets	
41	1450028	2	Ring Seals	
42	1451600	1	Control Assembly	
43	1450029	1	Six angle bar	

WINCH PARTS LIST (S9500SD)

No.	Part #	Qty	Description	Remark
1	950100	1	Motor Assembly	
2	95SD0001	6	Cap Screw M10 x 35	
3	95SD0002	6	Lock Washer Φ 10	
4	95SD0003	6	Think Flat Washer Φ 10	
5	95SD0004	6	Hex Flange Nut M10	
6	1200200	1	Break / Shaft Assembly	
7	1200005	2	Bushing—Drum	
8	95SD0006	2	Tie Bar	
9	95SD0007	1	Screw M8 x 10	
10	95SD0008	4	Think Flat Washer Φ 8	
11	95SD0009	4	Cap Screw M8 x 30	
12	95SD0300	1	Drum Assembly	
13	95SD0010	8	Screw M5 x18	
14	95SD0011	8	Lock Washer Φ 5	
15	1200012	1	End Bearing	
16	95SD0013	1	Gasket	
17	95SD0014	1	Gear—Ring	
18	95SD0400	1	Gear Carrier Assembly (Input)	
19	95SD0500	1	Gear Carrier Assembly (Intermediate)	
20	95SD0600	1	Gear Carrier Assembly (Output)	
21	95SD0015	1	Gear—Input Sun	
22	95SD0016	1	Trust Washer	
23	95SD0017	1	Gear—Housing	
24	95SD0018	1	Clutch Screw	
25	95SD0019	1	Ring Seals	
26	95SD0020	1	Clutch Cover	
27	1200021	1	Clutch	
28	95SDRS	1	Remote Control Switch (R8)	
29	95SD0800	1	Cable Assembly	
30	95SDWRS	1	Wireless Remote Control Switch	
31	95SD0900	1	Roller Fairlead	
32	95SD0022	1	Mounting Play	
33	95SD0023	1	Connecting Piece	
34	95SD0024	1	Connecting Piece	
35	95SD1300	1	Wireless Switch Receiver	
36	1201400	1	Relay with Screw Assembly	
37	951500	1	Cover with Screw Assembly	
38	95SD0025	1	Connecting Piece	
39	1200026	4	Connecting Block	
40	95SD0027	2	Connecting Rod Sets	
41	95SD0028	2	Ring Seals	
42	95SD1600	1	Control Assembly	
43	95SD0029	1	Six angle bar	

WINCH PARTS LIST (S9500HS)

No.	Part #	Qty	Description	Remark
1	1200100	1	Motor Assembly	
2	95HS0001	6	Cap Screw M10 x 35	
3	95HS0002	6	Lock Washer Φ 10	
4	95HS0003	6	Think Flat Washer Φ 10	
5	95HS0004	6	Hex Flange Nut M10	
6	1200200	1	Break / Shaft Assembly	
7	1200005	2	Bushing—Drum	
8	95HS0006	2	Tie Bar	
9	95HS0007	1	Screw M8 x 10	
10	95HS0008	4	Think Flat Washer Φ 8	
11	95HS0009	4	Cap Screw M8 x 30	
12	1200300	1	Drum Assembly	
13	95HS0010	8	Screw M5 x18	
14	95HS0011	8	Lock Washer Φ 5	
15	1200012	1	End Bearing	
16	95HS0013	1	Gasket	
17	95HS0014	1	Gear—Ring	
18	95HS0400	1	Gear Carrier Assembly (Input)	
19	95HS0500	1	Gear Carrier Assembly (Intermediate)	
20	95HS0600	1	Gear Carrier Assembly (Output)	
21	95HS0015	1	Gear—Input Sun	
22	95HS0016	1	Trust Washer	
23	95HS0017	1	Gear—Housing	
24	95HS0018	1	Clutch Screw	
25	95HS0019	1	Ring Seals	
26	95HS0020	1	Clutch Cover	
27	1200021	1	Clutch	
28	95HSRS	1	Remote Control Switch (R8)	
29	95HS0800	1	Cable Assembly	
30	95HSWRS	1	Wireless Remote Control Switch	
31	95HS0900	1	Roller Fairlead	
32	95HS0022	1	Mounting Play	
33	95HS0023	1	Connecting Piece	
34	95HS0024	1	Connecting Piece	
35	95HS1300	1	Wireless Switch Receiver	
36	1201400	1	Relay with Screw Assembly	
37	1201500	1	Cover with Screw Assembly	
38	95HS0025	1	Connecting Piece	
39	1200026	4	Connecting Block	
40	1200027	2	Connecting Rod Sets	
41	95HS0028	2	Ring Seals	
42	95HS1600	1	Control Assembly	
43	95HS0029	1	Six angle bar	

SPECIFICATION (S8000)

Rated line pulls	8000 lbs (35.56kN)
Gear reduction ratio	196:1
Motor	5.8hp / 4.3Kw(12V) 7.4hp / 5.5Kw(24V)
Overall dimensions	22" (L) x6.3" (W) x9.8" (H)/10.3" (H) 559(L)mmX160(W) mmX248(H)mm/262(H) mm
Drum size	Ø2.48" (D) x 8.8" (L) Ø 63(D) mm x223(L) mm
Cable	Ø 21/64" (D) x 95'(L) Ø 8.3mm (D) x29m (L)

DUTY CYCLE

Line speed and motor current (First layer)

Line pull lb (kN)	Line speed ft/min (m/min)		Motor current Amps (Max)	
	12V	24V	12V	24V
0	36(11.0)	44.3(13.5)	50	35
2000 (8.89)	17.4(5.3)	20.3(6.2)	125	90
4000 (17.78)	13.1(4.0)	15.7(4.8)	200	140
6000 (26.67)	10.5(3.2)	14.1(4.3)	260	150
8000 (35.56)	8.2(2.5)	10.8(3.3)	310	200

Line pull and cable capacity

Layer of cable	Rated line pull per Layer lb (kN)	Cable capacity per Layer ft (m)
1	8000 (35.36)	21.3 (6.5)
2	6620 (29.43)	46.9 (14.3)
3	5650 (25.12)	77.1 (23.5)
4	4920 (21.87)	95.1 (29)

SPECIFICATION (S9500)

Rated line pulls	9500 lbs (42.23kN)
Gear reduction ratio	196:1
Motor	6.1hp / 4.6Kw(12V) 7.8hp / 5.8Kw(24V)
Overall dimensions	22" (L) x6.3" (W) x9.8" (H)/10.3" (H) 559(L)mmX160(W)mmX248(H)mm/262(H)mm
Drum size	Ø2.48" (D) x 8.8" (L) Ø 63(D) mm x223 (L) mm
Cable	Ø 3/8" (D) x 85'(L) Ø 9.2mm (D) x 26m (L)

DUTY CYCLE

Line speed and motor current (First layer)

Line pull lb (kN)	Line speed ft/min (m/min)		Motor current Amps (Max)	
	12V	24V	12V	24V
0	36(11.0)	44.3(13.5)	50	35
2000 (8.89)	17.4(5.3)	20.3(6.2)	120	90
3000 (13.33)	15.4(4.7)	17.3(5.3)	150	105
6000 (26.67)	10.5(3.2)	14.1(4.3)	260	150
8000 (35.56)	8.2(2.5)	10.8(3.3)	300	200
9500 (42.23)	6.5(2.0)	8.5(2.6)	355	225

Line pull and cable capacity

Layer of cable	Rated line pull per Layer lb (kN)	Cable capacity per Layer ft (m)
1	9500 (42.23)	18 (5.5)
2	7600 (33.78)	39.4 (12)
3	6200 (27.56)	64 (19.5)
4	5400 (24.00)	85 (26.0)

SPECIFICATION (S12000)

Rated line pulls	12000 lbs (53.34kN)
Gear reduction ratio	253:1
Motor	6.7hp / 5.0Kw(12V) 8.0hp / 6.0Kw(24V)
Overall dimensions	22" (L) x6.3" (W) x9.8" (H)/10.3" (H) 559(L)mmX160(W)mmX248(H)mm/262(H)mm
Drum size	Ø2.48" (D) x 8.8" (L) Ø 63(D) mm x223(L) mm
Cable	Ø 13/32" (D) x 83.7'(L) Ø 10.2mm (D) x 25.5m (L)

DUTY CYCLE

Line speed and motor current (First layer)

Line pull lb (kN)	Line speed ft/min (m/min)		Motor current Amps (Max)	
	12V	24V	12V	24V
0	27.9(8.5)	36.1(11.0)	45	30
6000 (26.67)	11.5(3.5)	12.1(3.7)	200	130
8000 (35.56)	8.2(2.5)	10.5(3.2)	240	180
10000 (44.45)	5.9(1.8)	8.9(2.7)	300	220
12000 (53.34)	4.6(1.4)	7.9(2.4)	370	250

Line pull and cable capacity

Layer of cable	Rated line pull per Layer lb (kN)	Cable capacity per Layer ft (m)
1	12000 (53.34)	15.1 (4.6)
2	9533 (42.38)	34.1 (10.4)
3	7907 (35.15)	57.7 (17.6)
4	6755 (30.03)	83.7 (25.5)

SPECIFICATION (S14500)

Rated line pulls	12000 lbs (53.34KN)
Gear reduction ratio	253:1
Motor	7.2hp / 5.4Kw(12V) 8.3hp / 6.2Kw(24V)
Overall dimensions	23.35" (L) x6.30" (W) x9.80" (H) /10.3" (H) 593(L) mm X 160(W) mm X 248 (H) mm/262(H) mm
Drum size	Ø2.48" (D) x 8.8" (L) Ø 63(D) mm x223(L) mm
Cable	Ø 13/32" (D) x 83.7'(L) Ø 10.2mm (D) x 25.5m (L)

DUTY CYCLE

Line speed and motor current (First layer)

Line pull lb (kN)	Line speed ft/min (m/min)		Motor current Amps (Max)	
	12V DC	24V DC	12V DC	24V DC
0	27.9(8.5)	36.1(11.0)	45	30
6000 (26.67)	11.5(3.5)	13.8(4.2)	200	130
8000 (35.56)	7.87(2.4)	10.5(3.2)	245	160
10000 (44.45)	5.57(1.7)	8.9(2.7)	310	190
12000 (53.34)	4.92(1.5)	7.9(2.4)	380	230
14500 (64.45)	2.6(0.8)	4.26(1.3)	460	300

Line pull and cable capacity

Layer of cable	Rated line pull per Layer lb (kN)	Cable capacity per Layer ft (m)
1	14500 (64.45)	15.1 (4.6)
2	11519 (51.2)	34.1 (10.4)
3	9556 (42.48)	57.7 (17.6)
4	8163 (36.28)	83.7 (25.5)

SPECIFICATION (S9500SD)

Rated line pulls	9500 lbs (42.23kN)
Gear reduction ratio	196:1
Motor	6.1hp / 4.6Kw(12V) 7.8hp / 5.8Kw(24V)
Overall dimensions	18" (L) x6.3" (W) x9.8" (H) /10.3" (H) 456(L)mmX160(W)mmX248(H)mm/262(H)mm
Drum size	Ø2.48" (D) x 4.7" (L) Ø 63(D) mm x120 (L) mm
Cable	Ø 3/8" (D) x 45.9'(L) Ø 9.2mm (D) x 14.0m (L)

DUTY CYCLE

Line speed and motor current (First layer)

Line pull lb (kN)	Line speed ft/min (m/min)		Motor current Amps (Max)	
	12V	24V	12V	24V
0	36(11.0)	44.3(13.5)	50	35
2000 (8.89)	17.4(5.3)	20.3(6.2)	120	90
3000 (13.33)	15.4(4.7)	17.3(5.3)	150	105
6000 (26.67)	10.5(3.2)	14.1(4.3)	260	150
8000 (35.56)	8.2(2.5)	10.8(3.3)	300	200
9500 (42.23)	6.5(2.0)	8.5(2.6)	355	225

Line pull and cable capacity

Layer of cable	Rated line pull per Layer lb (kN)	Cable capacity per Layer ft (m)
1	9500 (42.23)	9.8(3.0)
2	7600 (33.78)	24.6 (7.5)
3	6200 (27.56)	42.7(13.0)
4	5400 (24.00)	45.9 (14.0)

SPECIFICATION (S9500HS)

Rated line pulls	9500 lbs (42.23kN)
Gear reduction ratio	196:1
Motor	8.6 hp / 6.4kW (DC 12V) 10.7hp /8.0kW (DC 24V)
Overall dimensions	23.35" (L) x6.30" (W) x9.80" (H) /10.3" (H) 593(L)mmX160(W)mm X 248 (H) mm/262(H) mm
Drum size	Ø2.48" (D) x 8.8" (L) Ø 63(D) mm x223(L) mm
Cable	Ø 3/8" (D) x 85'(L) 9.2mm (D) x 26m (L)

DUTY CYCLE

Line speed and motor current (First layer)

Line pull	Line speed ft/min (m/min)		Motor current Amps (Max)	
	12V	24V	12V	24V
lbs (kN)				
0	39.4(12)	42.6(13)	45	31
4000(17.78)	15.7(4.8)	18.0(5.5)	190	100
6000(26.67)	13.1(4.0)	16.4(5.0)	250	145
8000(35.56)	10.5(3.2)	13.8(4.2)	310	185
9500(42.23)	9.2(2.8)	12.5(3.8)	365	215

Line pull and cable capacity

Layer of cable	Rated line pull per Layer lbs (kN)	Cable capacity per Layer ft (m)
1	9500 (42.23)	15.1 (4.6)
2	7600 (33.78)	34.1 (10.4)
3	6200 (27.56)	57.7 (17.6)
4	5400 (24.00)	85.3 (26.0)

Limited lifetime with 3 year on electrical
Limited Lifetime Warranty for WARRIOR WINCHES

Winch Solutions are the sole distributors of WARRIOR WINCHES.

Winch Solutions ("seller" or winch solutions) warrants to the original retail buyer only ("Buyer") that any mechanical component of a genuine WARRIOR WINCH ("product") is free of defects in material and workmanship for the lifetime of the winch.

The electrical components (including the motor, contactor, and switches) will be free of defects in material and workmanship for a period of (3) three years (36 Months) from the original purchase provable date of purchase.

Any product Winch Solutions determines to be defective will be repaired or replaced at Winch Solutions sole discretion without charge to the Buyer upon Buyer's compliance with this procedure. Seller or its Authorized Agent may make reasonable charges for parts and for labour for repairs not covered by this Lifetime Limited Warranty. The warranties set forth herein are exclusive and in lieu of all other warranties, whether oral or written, express or implied.

All purchases must be registered. Any product that has not been registered will be covered by the standard 1 year warranty.

To obtain service under this warranty, the Buyer shall mail, ship or otherwise deliver to the address noted below, at the Buyers expense; (1) the Product, (2) a written description of the problem, (3) Buyers name, address and contact number, (4) copy of the original purchase receipt.

The Warranty does not cover the cost of labour or transportation/shipping charges for the replacement or installation of defective parts.

This warranty does not apply to defects of the Product caused by; (1) normal wear and tear, (2) failure to comply with any installation or maintenance instructions provided by the Seller, including but not limited to subjecting the product to loads in excess of the loads listed in any instructions, Owners Manual or as detailed upon the Sellers website, (3) commercial or industrial use, (4) alteration or modification by any parties other than the Seller, (5) misuse, abuse, neglect, accidents, Acts of God, terrorism or (6) other causes beyond the control of the Seller after delivery of the Product to the Sellers Authorized Agent.

This Warranty does not cover cables, synthetic ropes, fairleads or exterior finishes

Winch Solutions shall not be responsible or liable for any indirect or consequential damages. These consequential damages may include, but are not limited to, lost profits or loss of use and down time.

Winch Solution reserves the right to change the Product design without notice. Winch Solutions reserves the right to replace any part or whole unit with a newer design of the same function.

Please ensure you record the information below:

Distributor	
Date of Purchase	
Invoice No	
Serial No	

Please register your Winch at www.warriorwinch.co.uk , any product that is not registered will not be covered by the lifetime warranty.

In the unlikely event you experience problems, contact the distributor with this information.